

OH08B 8-megapixel product brief



Industry's First 8 Megapixel Medical-Grade Image Sensor with Nyxel® Technology for Single-Use and Reusable Endoscopes



available in
a lead-free
package

OmniVision's next-generation OH08B CMOS image sensor is the first 8 megapixel (MP) resolution sensor for single-use and reusable endoscopes, along with the OH08A. Targeted at endoscopes with a 10-12 mm outer diameter, such as gastroscopes, duodenoscopes, amnioscopes, laparoscopes and colonoscopes, the OH08B delivers high image quality, up to 4K2K resolution at 60 fps, greatly improving the doctor's ability to visualize the human anatomy during these important procedures. Additionally, the OH08B is the first medical-grade image sensor to use OmniVision's award-winning Nyxel® near-infrared (NIR) technology—bringing revolutionary imaging capabilities beyond the visible spectrum to the medical industry. The sensor offers better performance in color and IR sensitivity, enabling doctors to see sharper video during NIR, fluorescence, chromo-endoscopy and virtual endoscopy procedures. Also, higher sensitivity results in less illumination, thus reducing the heat at the tip of the endoscope.

The OH08B has a 1/1.8-inch optical format and uses a larger 2.0 μm PureCel® pixel in a 8.9 x 6.3 mm package. The sensor features OmniVision's Nyxel® technology, providing 3x quantum efficiency (QE) improvement at both the 850 nm and 940 nm NIR wavelengths. The excellent QE also allows the use of lower-power IR illumination, resulting in significantly reduced chip-on-tip power consumption.

Other key features of the OH08B include a 11 degree chief ray angle, enabling the use of lenses with large field of view and short focus distance, pulse width modulation output LED drivers, and 4 lane MIPI output with raw data. This sensor is stereo ready with frame synchronization to support a host of depth perception applications. Plus it's autoclavable for reusable endoscope sterilization.

Find out more at www.ovt.com.



OmniVision

Applications

- Medical Endoscopes
- Medical and Dental Equipment

Product Features

- 2 μm x 2 μm pixel
- optical size of 1/1.8"
- QE enhancement in 850 nm and 940 nm
- programmable controls for:
 - frame rate
 - mirror and flip
 - cropping
 - windowing
- supports output formats: 12-/10-bit RAW RGB
- supports images sizes:
 - 3840 x 2160
 - 2560 x 1440
 - 1920 x 1080
 - 1280 x 720
- embedded 2k bits of one-time programmable (OTP) memory
- supports 2x2 binning
- standard serial SCCB interface
- 12-bit ADC
- up to 4-lane MIPI/LVDS serial output interface (supports maximum speed up to 1500 Mbps/lane)
- 2-exposure staggered HDR support
- programmable I/O drive capability
- light sensing mode (LSM)
- PLL with SSC support
- support for FSIN

OH08B



Ordering Information

- OH08B10-A92A-001A-Z (color, lead-free) 92-pin CSP

Technical Specifications

- active array size: 3840 x 2160
- maximum image transfer rate:
 - 4K2K: 60 fps
 - 2560 x 1440: 60 fps
- power supply:
 - core: 1.2V
 - analog: 2.8V
 - I/O: 1.8V
- power requirements:
 - active: 240 mA
 - active: <10 μA
- temperature range:
 - operating: -30°C to +85°C junction temperature
 - stable image: 0°C to +60°C junction temperature
- output format: 10/12-bit RAW RGB
- lens size: 1/1.8"
- lens chief ray angle: 11° linear
- scan mode: progressive
- pixel size: 2.0 μm x 2.0 μm
- image area: 7736.256 μm x 4379.616 μm
- package dimensions:
 - CSP: 8939.2 μm x 6340 μm

Functional Block Diagram

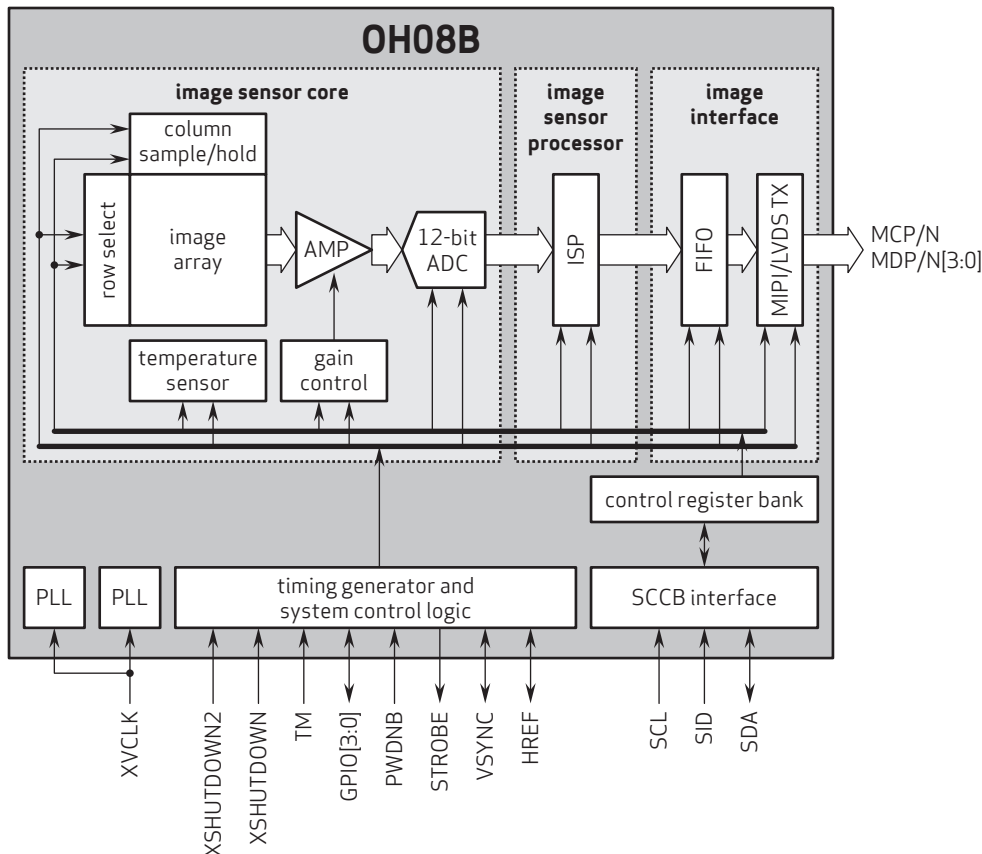

4275 Burton Drive
Santa Clara, CA 95054
USA

Tel: +1 408 567 3000
Fax: +1 408 567 3001
www.ovt.com

OmniVision reserves the right to make changes to their products or to discontinue any product or service without further notice. OmniVision, the OmniVision logo, PureCel and Nyxel are registered trademarks of OmniVision Technologies, Inc. All other trademarks are the property of their respective owners.



OmniVision